

# **FUJISPRAY<sup>®</sup>**

## **PRESSURE POT 2.5 GALLON (NON-ASME)**

### **USER MANUAL**

---



# Contents

**Contents and Specifications ..... 1**

**Safety Precautions ..... 2 - 3**

**Assembly..... 3**

**Installation and Operation ..... 4 - 5**

**Pressure Relief Procedure ..... 5**

**Cleaning and Storage ..... 5**

**Troubleshooting..... 5**

**Parts Diagram ..... 6**

**Warranty..... 7**

**Service Information..... 7**

SPECIFICATIONS	
Maximum Air Supply Pressure	60 PSI (4.1 bar)
Safety Valve Setting	60 PSI (4.1 bar)
Air Inlet Size	1/4" NPS (M)
Fluid Outlet Size	3/8" NPS (M)

## Please read these instructions before using the equipment



### **FIRE AND EXPLOSION HAZARD**

**Equipment must not be used in an area contaminated by volatile or flammable materials. This could ignite the contaminants causing a dangerous explosion.**

- Do not spray flammable or combustible materials near an open flame or sources of ignition such as cigarettes, motors, and electrical equipment.
- Never use 1,1,1-trichloroethane, methylene chloride, other halogenated hydrocarbon solvents or fluids containing such solvents in equipment with aluminum wetted parts. Such use could result in a serious chemical reaction, with the possibility of explosion. Consult your fluid suppliers to ensure that the fluids being used are compatible with aluminum parts.
- Keep spray area well-ventilated. Keep a good supply of fresh air moving through the area.
- Do not smoke in the spray area.
- Do not operate light switches, engines, or similar spark producing products in the spray area.
- Keep area clean and free of paint or solvent containers, rags, and other flammable materials.
- Fire extinguisher equipment shall be present and working.



### **TOXIC FLUID OR FUMES HAZARD**

**Toxic fluids or fumes can cause serious injury or death if splashed in the eyes or on skin, inhaled, or swallowed.**

- Read MSDS (Material Safety Data Sheet) to know the specific hazards of the fluids you are using.
- Always wear appropriate gloves and eye protection; during cleaning and flushing, solvents can be forcefully expelled from fluid and air passages. Some solvents can cause eye injury.
- Always wear a respirator. Read all instructions of the respirator to ensure that it will provide the necessary protection against the inhalation of harmful vapors. Also check with the local jurisdiction.
- Paint, solvents, insecticides and other materials may be harmful if inhaled.
- Store hazardous fluid in approved containers and dispose of it according to applicable guideline.
- Do not stop or deflect fluid leaks with your hand or body.



### **EQUIPMENT MISUSE HAZARD**

**Misuse of equipment can cause serious injury or death.**

- Health and safety, accident prevention, work and environment protection regulations and policies are mandatory.
- Never aim the spray gun at another person or animal. In the event of injury, seek expert medical attention immediately.
- Do not operate or spray near children. Keep children away from equipment at all times.
- Do not overreach or stand on an unstable support. Keep effective footing and balance at all times.
- Stay alert and watch what you are doing.
- Do not operate the unit when fatigued or under the influence of drugs or alcohol.
- Check the hose, hose connectors and Spray Gun before every use. Any worn or damaged parts should be replaced immediately.
- Before performing any maintenance to the equipment, de-energize, depressurize, disconnect and lock out all power sources.
- Use only genuine Fuji Spray replacement parts.
- Do not drill into, weld, heat or modify tank in any way.
- The safety valve is set to 60 PSI. Exceeding the working pressure will cause the safety valve to release air. DO NOT ADJUST.

· Never use abrasive or corrosive materials. Also, do not use materials that can cause rust, and or thinners and coatings with solvents that are too hot / strong for the tank coating. This tank is not designed for use with these types of materials, using them can damage the tank's coating and parts causing them to fail. Always test material for tank compatibility prior to spraying.

**STATIC CHARGE** - Static electricity is created by the flow of fluid through the pressure tank and hose. To prevent ignition sources from static discharges, all parts of tank and all metallic equipment should be grounded.

If pressure pot is to be used for spraying flammable materials, pot should not exceed 15 PSI in accordance with OSHA requirements. Operator assumes the responsibility of following this procedure.



**Prop 65 Warning for California Residents**

**WARNING:** This product may contain chemicals known to the State of California to cause cancer, birth defects, or other reproductive harm.

**Warning:** Sound levels produced by spray guns during use may be harmful to the ear depending on the set-up. It is recommended that ear protection is worn at all times when spraying.

**THE EMPLOYER IS RESPONSIBLE TO PROVIDE THIS INFORMATION TO THE OPERATOR OF THE EQUIPMENT**

**ASSEMBLY**

The only assembly required for the 2.5 gallon pressure pot right out of the package, is installing the casters to the base of the pot, see below.

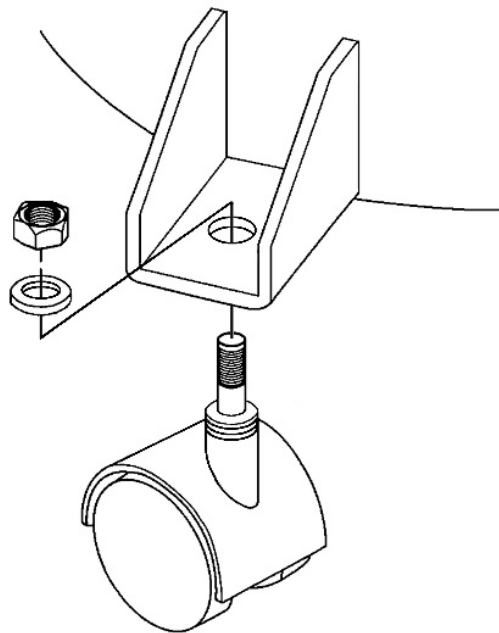

**Installation of the casters (x4)**

## INSTALLATION AND OPERATION

1. Attach the fluid hose and air hose to the spray gun (supply hose and spray gun sold separately)
2. Connect the other end of the fluid hose and air hose to the pressure pot's outlets. Ensure both fluid and air connections are secure to prevent any leaks
3. Make sure the pot's shut-off valve is on the "off" position, and pressure regulator is set to zero pressure (counter-clockwise)

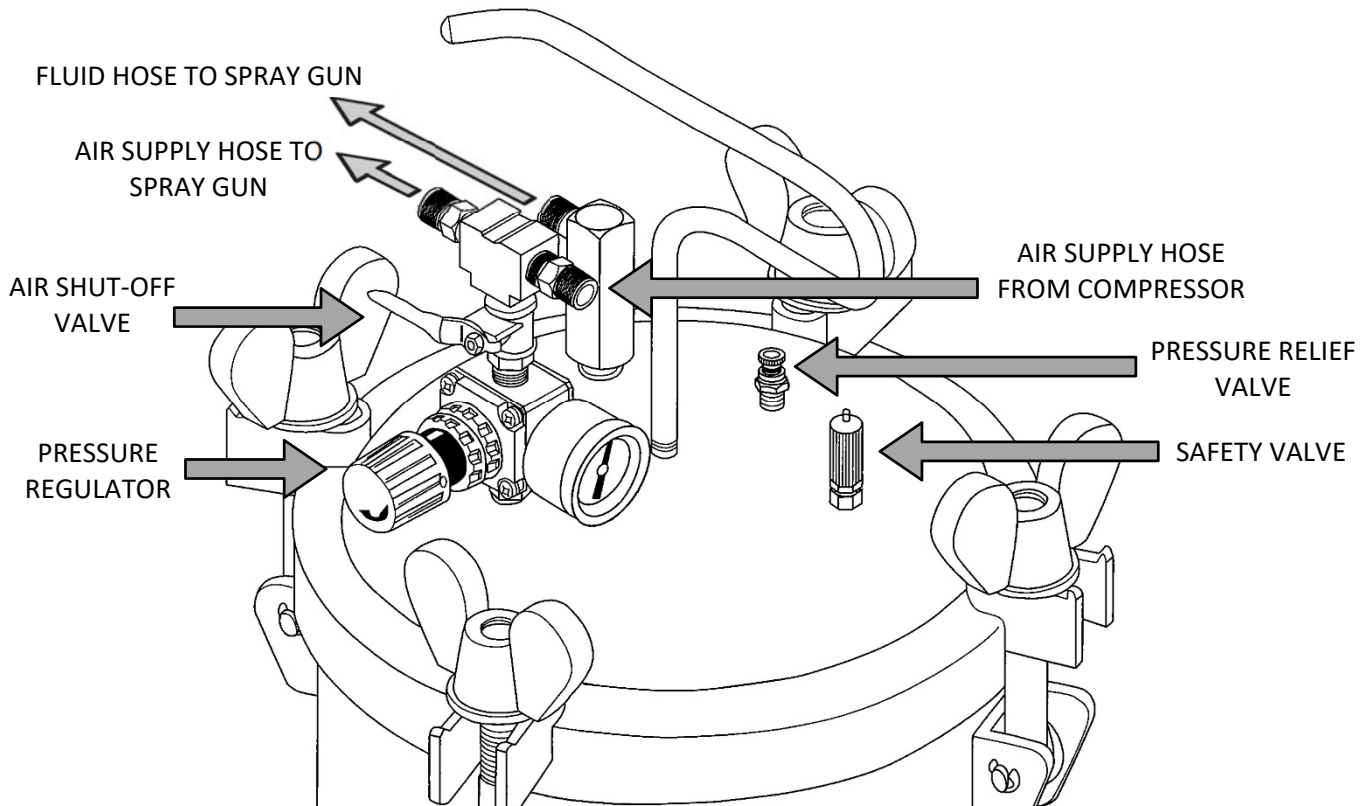

4. Pour the prepared and strained material inside the pressure pot and secure lid by following the tightening sequence shown below with the wing nuts. When refilling the pot, do not overfill, leave at least 2 inches between the pot's lid and material level. A one-gallon paint can will fit inside the pressure pot as well.

**TIGHTEN SEQUENCE:** 1. → 2. → 3. → 4.

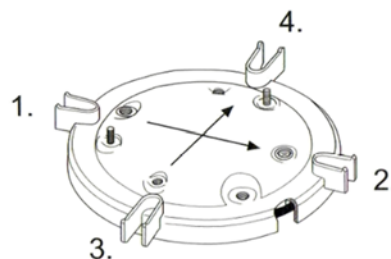

5. Attach the air supply from the compressor to pressure pot
6. Set your air compressor to approximately 60 PSI
7. Slowly open the pot's shut-off valve and set the pot's pressure to approximately 20 PSI, which is the pot's average operating pressure. Pull the trigger of the spray gun to adjust the pot's pressure
8. Make sure spray gun's air inlet pressure is also adjusted accordingly

**NOTE:** The most efficient spray gun air pressure is the lowest air pressure that will properly atomize the material. This will minimize overspray, increase transfer efficiency and eliminate material waste. If a faster coverage is necessary, first increase fluid pressure and then adjust atomization air pressure. If a slower coverage is more desirable, first reduce the fluid pressure and then adjust spray gun inlet pressure. Always attempt to maintain the lowest pressure for maximum efficiency. Air supply must be clean, moisture free, oil free air and properly regulated.

**PRESSURE RELIEF PROCEDURE**

1. Turn the pot’s shut-off valve to the “OFF” position
2. Slowly unscrew the pressure relief valve to de-pressurize the pot (see diagram on pg.4)
3. When the pot’s pressure gauge indicates zero, unscrew the wing nuts and remove the pot’s lid

**CLEANING AND STORAGE**

To get the best use and longest life from your pressure pot, it is very important to clean it out properly.

1. Turn off air supply to pressure pot
2. Perform pressure relief procedure (above)
3. Tip the pot’s lid on its side, with pick-up tube still inside the pot
4. Turn on the air supply, the air pressure is directed only to the spray gun
5. Hold a cloth tightly against the air cap and nozzle of the spray gun and pull the trigger. This will cause material flowback through the fluid hose and back into the pot
6. Empty contents from the pot and clean, also clean areas and components that may have come in contact with material inside the pot
7. Pour some water or suitable clean solvent inside the pressure pot
8. Secure the lid to the pressure pot and be sure to follow the tightening sequence with the wing nuts
9. Spray the water or solvent until it starts coming out clear
10. Repeat this process as necessary

**TROUBLESHOOTING**

PROBLEM	CAUSE	FIX
Indicator on air pressure gauge not reading pressure	Broken or damaged	Discontinue tank use until pressure gauge is replaced
Material or air leak from lid gasket	Lid gasket is worn, or lid is not secured tight enough	Replace gasket or securely tighten the lid
Air leak from pressure release valve after being tightened	The O-ring may be damaged	Replace pressure release valve O-ring
Material does not come out smoothly	Pick-up tube filter or fluid hose may be dirty	Check and/or replace inlet filter. Clean fluid hose
Air safety valve fails to open	Valve assembly may be damaged	Discontinue tank use and replace tank / lid assembly
<b>Note:</b> Check pressure gauge occasionally. The indicator should read zero whenever there is no pressure in the tank.		

## 2.5 GALLON PRESSURE POT

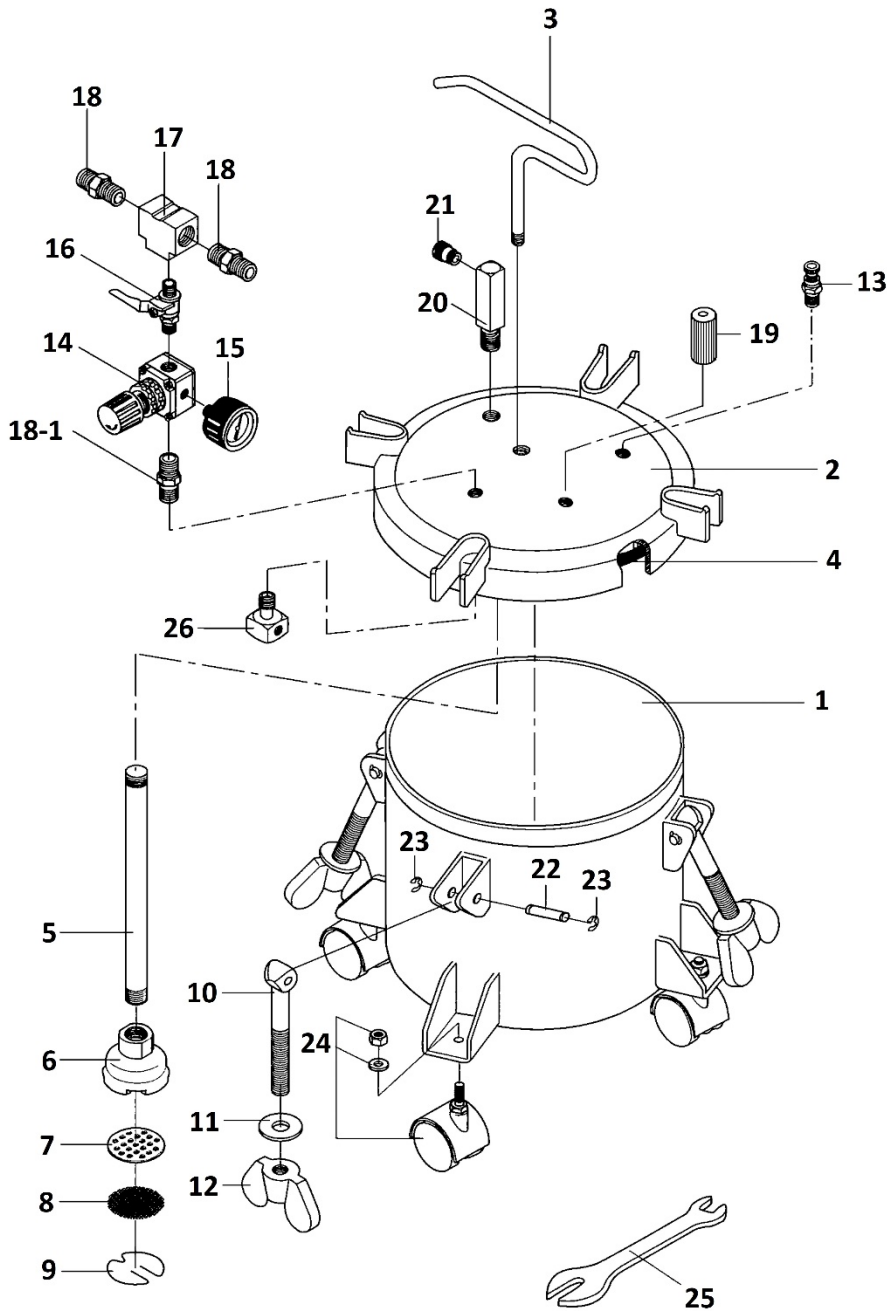

Part #	Description
1	Material Tank
2	Lid Assembly
3	Handle
4	Gasket
5	Pickup Tube
6	Filter Housing
7	Filter Base
8	Material Filter
9	Snap Ring
10	Locking Arm
11	Washer
12	Thumb Nut
13	Pressure Relief Valve
14	Pressure Regulator
15	Pressure Gauge
16	Air Shut-off Valve
17	T-connector
18	Air Adapter
18-1	Adapter
19	Safety Valve
20	Fluid Outlet Adapter
21	Fluid Outlet Coupler
22	Pin
23	Locking Ring
24	Caster Assembly
25	Wrench
26	Air Flow Guide

### **Fuji Limited 1 year warranty**

Fuji Industrial Spray Equipment LTD. ("Fuji") provides a 12 month limited warranty on the product to the original purchaser effective from the date of purchase against defects in materials and workmanship.

The warranty does not cover damage or defects arising as a result of abuse, misuse, accident, negligence, malfunction, corrosion, normal wear and tear, inadequate or lack of spray gun or other aspects of maintenance of the product, damage arising from improper assembly, installation or operation or damage arising from the product being used for a purpose other than that for which it was designed or intended. The warranty is void if repairs to the product are made or attempted by anyone other than Fuji or its authorized agent, or if any modifications to the product are made or attempted.

#### **For SERVICE & PARTS**

##### **USA**

###### **Cogent Bathtub Refinishing Coatings**

Phone: 862-238-7224      **Online:** [www.cogentcoatings.com](http://www.cogentcoatings.com)

###### **hvlp.net**

Phone: 800-650-0930      **Online:** [www.hvlp.net](http://www.hvlp.net)

###### **Phelps Refinishing**

Phone: 800-377-5662      **Online:** [www.phelpsrefinishing.net](http://www.phelpsrefinishing.net)

###### **Paint Sprayers Plus**

Phone: 877-293-5826      **Online:** [www.paintsprayersplus.com](http://www.paintsprayersplus.com)

##### **CANADA**

###### **Fuji Spray**

Phone: 800-650-0930      Local: 416-650-1430

###### **hvlp.ca**

Phone: 800-650-0930      **Online:** [www.hvlp.ca](http://www.hvlp.ca)

##### **UNITED KINGDOM**

###### **Axminster Power Tool Centre** Axminster, Devon, England

Phone: 01297 33656      **Online:** [www.axminster.co.uk](http://www.axminster.co.uk)

##### **AUSTRALIA & NZ**

###### **Spraychief Industries** Campbellfield, Victoria 3061

Phone: 03-9357-8788      **Online:** [www.spraychief.com.au](http://www.spraychief.com.au)

##### **PUERTO RICO**

###### **Eagle Tools Mfg. Corp** San Lorenzo, Puerto Rico, 00754

Phone: 787-736-0444

###### **Fra-Marson Warehouse Distributors** San Juan PR, 00926

Phone: 787-761-4810

##### **RUSSIA**

###### **varnishop.ru** St. Petersburg, Russia

Phone: 812-242-8040      **Online:** [www.varnishop.ru](http://www.varnishop.ru)

Copyright © 2018 Fuji Spray® Toronto, Canada